

DIMENSIONS						UNIT : mm								
NOMINAL DIAMETER	L	FLANGE		H1	H2	H3	E	FLANGE RATING : JIS 10K						
		∅C	n-∅h					40A	50A	63	80	100	125	150
40A	41	105	2-19	63	120	150	170							
50A	41	120	2-19	63	120	150	170							

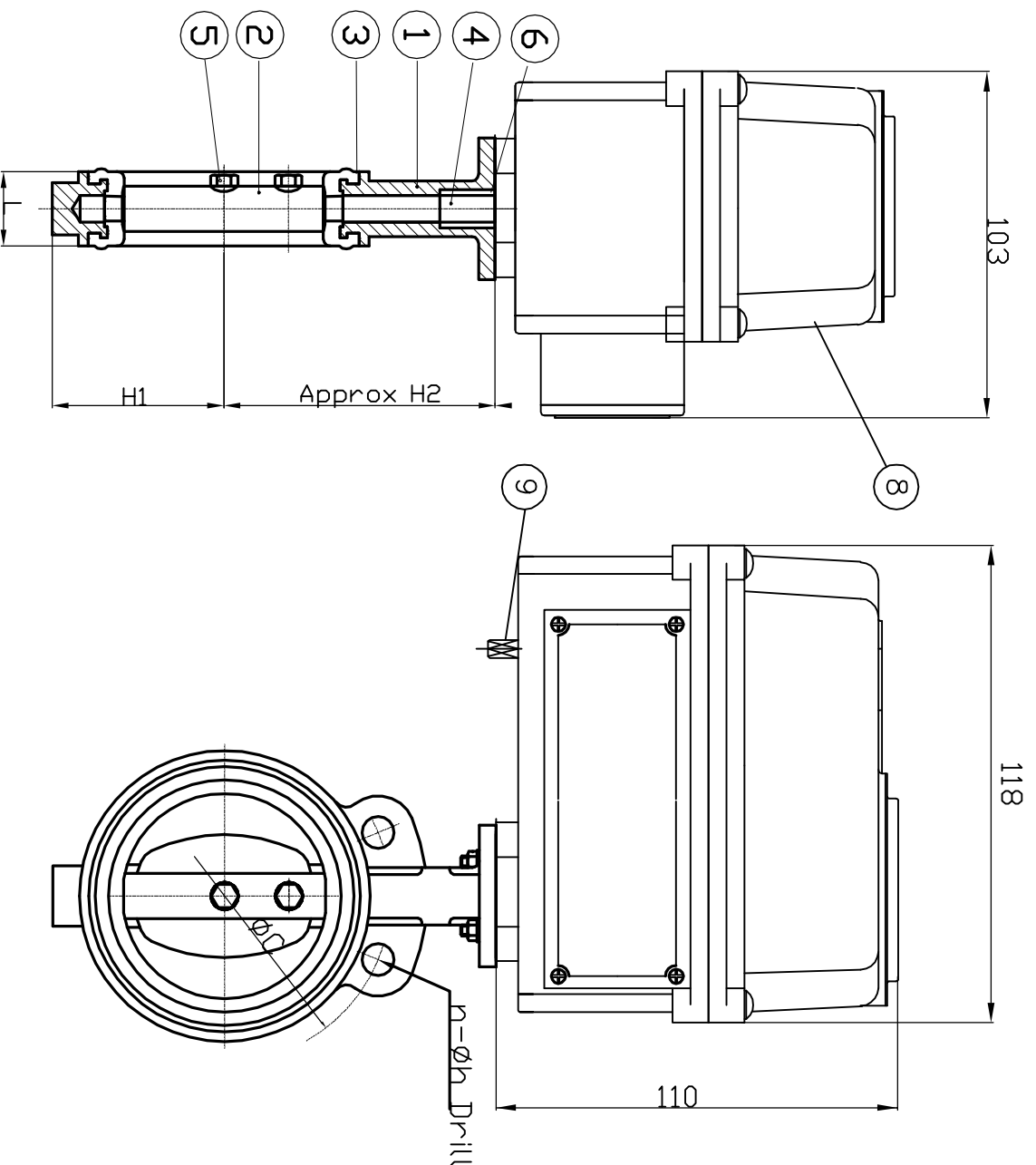

9	HAND WHEEL	SS41	1		
8	ACTUATOR	AC4C	1		
7	BOLT & NUT	SS41	4		
6	PACKING	EPDM	1		
5	DISC BOLT	SUS304	2		
4	STEM	SUS304	1		
3	SEAT	EPDM	1		
2	DISC	SCS13	1		
1	BODY	FC 20	1		
ND	PART NAME	MATERIAL	Q'TY	REMARKS	
△	FIRST ISSUE	05.04.15			
REV NO	REVISION	NOTE	DATE	DRW	APP

ELECTRIC BUTTERFLY VALVE

FILE NAME 40-50A

DWG	DES'N	CHK'D	APP'D	SCALE	NS
				DWG	ND
				PCM-04-07	

