

DIMENSIONS							UNIT : mm		
ND	A	B	H1	H2	n- $\phi$ h	$\phi$ C	$\phi$ D	L	
125A	348	165	192	190	8-23	210	250	356	
150A	400	187.5	198	220	8-23	240	280	394	

FLANGE RATING : JIS 10K

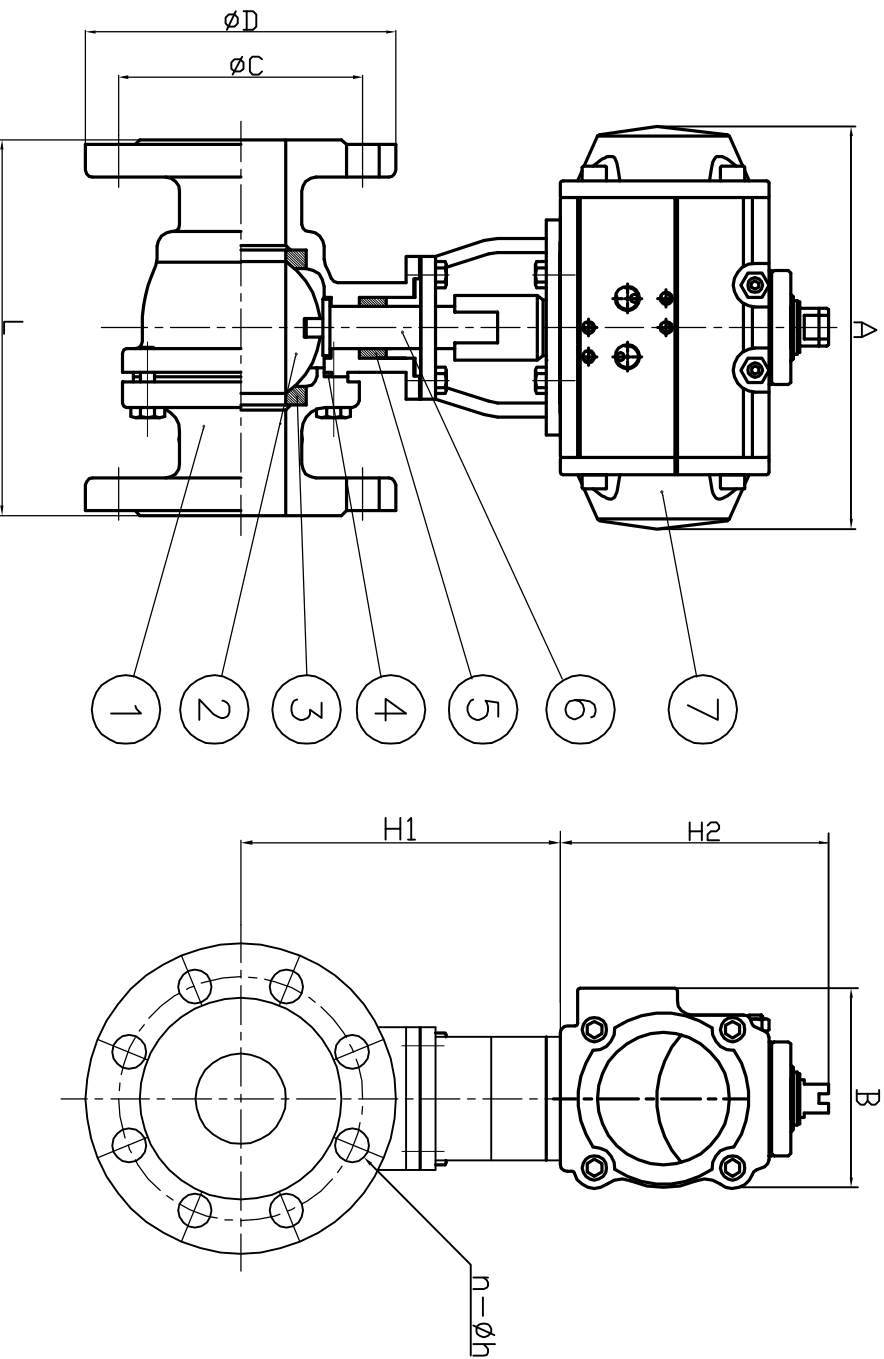

7	ACTUATOR					
6	STEM	STS304	1			
5	V-PACKING	PTFE	1			
4	PACKING	PTFE	1			
3	SEAT	PTFE	1			
2	BALL	SSC13	1			
1	BODY	SSC13	1			
P.NO.	PART NAME	MATERIAL	Q'TY	REMARK		
$\triangle$	FIRST ISSUE	06.05.22				
REV NO	REVISION NOTE	DATE	DRW	APP		

PNEUMATIC BALL VALVE

FILE NAME	125-150A				
DWG	DES'N	CHK'D	APP'D	SCALE : N/S	DWG NO
					PCD-014

